

# SQ-04N Cloud

Technical support

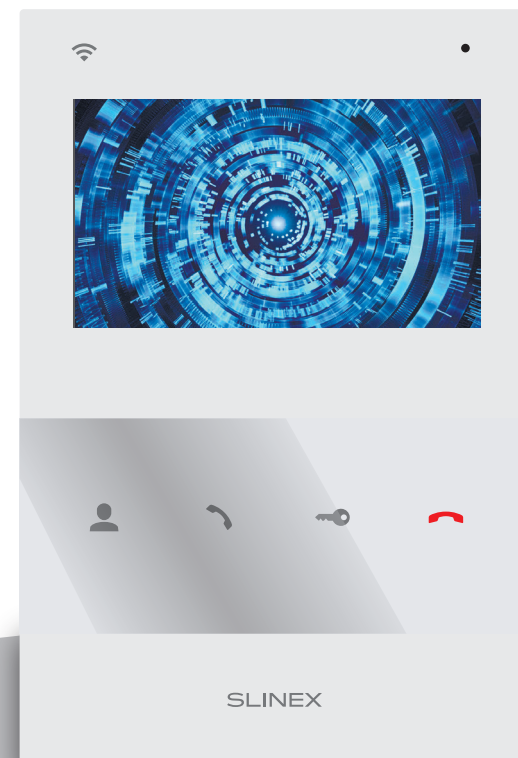

Техническая  
поддержка



User manual



Инструкция по эксплуатации

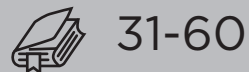

Attention!



As a result of continuous upgrades and functionality improvements, technical characteristics of the device can be changed without any preliminary declaration. This manual can contain some inaccuracy or misprint. The owner reserves the right to make corrections to the information described in the user manual and device package. The last revision of this manual is available on [www.slinex.com](http://www.slinex.com)

### Safety instructions

Read and keep that manual.

The device installation process should be carried out by the qualified specialists.

Use the device from -10 °C to +55 °C, always keep it within that temperature range.

Installation surface should be free from vibration and impact influence.

Keep this device far from open sources of heat, such as radiators, heaters, and ovens.

The device can be installed near other electronic equipment in case if the temperature of the environment does not exceed previously mentioned range.

The device should be protected from the direct influence of the natural phenomena, such as direct sunlight, rain or snow.

Don't use aggressive or abradant detergent for the device surface cleaning.

Use soft wet cloth or tissue to remove strong dirt.

Don't overpower outlets. It can cause fire or electric shock.

### Nature protection



Don't throw away the device with other industrial or nutritive trash if you see that symbol. Some regions have separation and recycling systems for the electronic equipment. Connect with local authorities to receive information about recycling of electronic equipment for your region.

### Rights and limitation of liability

All rights reserved. Any part of that document can not be published in any form, translated into other languages or reproduced in any way including electronic or mechanical.

Document recording and copying is strictly denied without owner permission.

### Table of contents

- 1. Package ..... 3
- 2. Specification ..... 3
- 3. Description ..... 4
- 4. Installation ..... 5
  - 4.1. Cable requirements ..... 5
  - 4.2. Schematic diagrams ..... 6
  - 4.3. Unit mount ..... 8
- 5. Operation ..... 9
  - 5.1. Incoming call ..... 9
  - 5.2. Outdoor panel and camera image monitoring ..... 10
  - 5.3. Incoming call redirection ..... 11
  - 5.4. Intercom ..... 12
- 6. Main menu ..... 12
  - 6.1. Devices ..... 13
  - 6.2. System setting ..... 15
  - 6.3. Network setting ..... 16
  - 6.4. Silent mode ..... 17
  - 6.5. Files playback ..... 17
  - 6.6. Maintenance ..... 18
- 7. Image and talking volume settings ..... 19
- 8. Network connection diagrams ..... 20
- 9. Software ..... 21
  - 9.1. New account registering ..... 21
  - 9.2. Wired network connection steps ..... 21
  - 9.3. Wireless Wi-Fi network connection steps in «AP mode» ..... 23
  - 9.4. Wireless Wi-Fi network connection steps in «EZ mode» ..... 24
  - 9.5. Operation ..... 25
  - 9.6. Sharing with the other devices ..... 27
  - 9.7. Notification messages ..... 28
- 10. Limited Warranty ..... 29

## 1. Package

SQ-04N Cloud indoor monitor – 1 pc.  
 Wall mounting bracket – 1 pc.  
 Connection wires – 1 pkg.  
 Mounting screws and nuts – 1 pkg.  
 User manual – 1 pc.

## 2. Specification

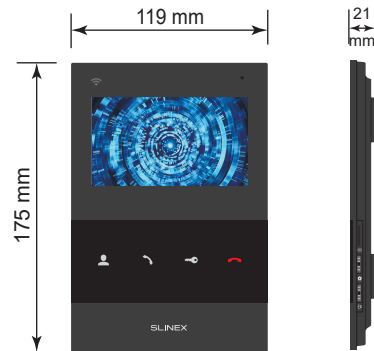

SCREEN 4.3", color IPS	STANDBY MODE POWER CONSUMPTION 1 W
RESOLUTION 480x272 px.	WORKING MODE POWER CONSUMPTION 7.5 W
VIDEO SYSTEM PAL / NTSC / AHD, TVI, CVI (720p,1080p)	POWER SUPPLY Built-in power supply, ~100–240 V
AUDIO TYPE Half duplex	MOUNTING TYPE Surface mount
CALL DURATION 120 seconds	DIMENSIONS 175x119x21 mm (6.89x4.68x0.83")
MEMORY MicroSD card, up to 64 Gb	WORKING TEMPERATURE -10 ... +55 °C (+14...+131 °F)

## 3. Description

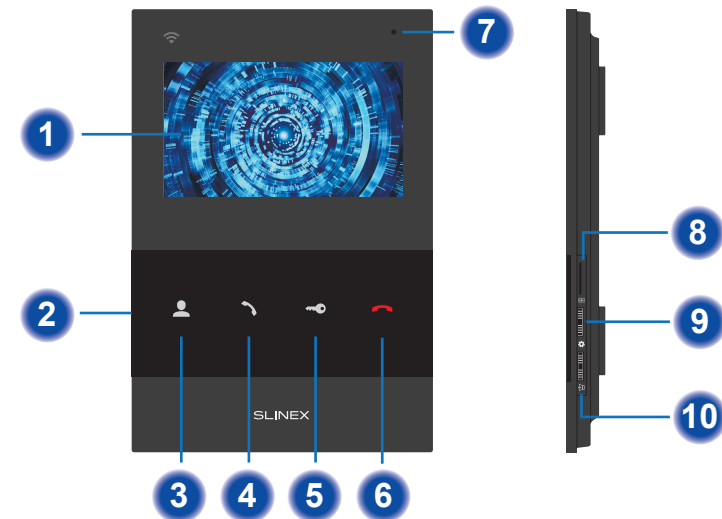

- 1 Display
- 2 Power switch
- 3 «Monitor» button – door panel or camera image monitoring
- 4 «Answer» button – incoming call answer and start talking with the visitor
- 5 «Unlock» button – door unlocking
- 6 «Hang Up» – stop conversation with the visitor / settings menu exit
- 7 Microphone
- 8 microSD card slot;
- 9 Settings joystick:
  - press the joystick while monitoring to save a photo or video;
  - press the joystick in standby mode to enter settings menu;
  - move the joystick up or down to move through the settings menu (next/previous parameter);
  - press the joystick on any parameter to change its value. Change the value of the current parameter by moving joystick up or down and then press the joystick again to save the parameter;
- 10 Volume joystick:
  - press the joystick during conversation to enable talking volume control bar;
  - move the joystick up or down during conversation to increase or decrease talking volume.

## 4. Installation

### 4.1. Cable requirements

Disconnect all power cables before device installation.

Cable type that is used for device connection depends on the distance between the last indoor monitor in the system and outdoor panel:

a) Use 4-wire cable with such parameters:

- distance up to 25 meters (82 ft.) use a cable with 0,22 mm<sup>2</sup> square of one wire (AWG 24);
- distance 25 to 50 (82-164 ft.) meters use a cable with 0,41 mm<sup>2</sup> square of one wire (AWG 21);
- distance 50 to 100 meters (164-328 ft.) use a cable with 0,75 mm<sup>2</sup> square of one wire (AWG 18).

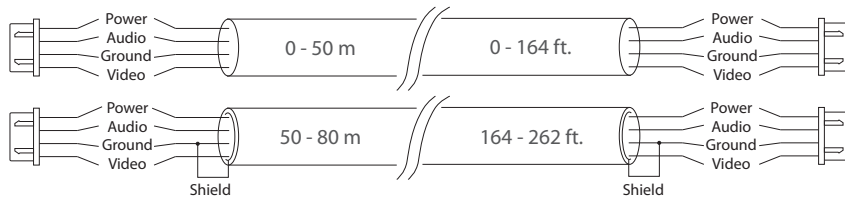

b) If the distance between door monitor and door panel is between 80 and 100 meters (262-328 ft.) then use a 3-wire cable with 0,75 mm<sup>2</sup> (AWG 18) square of one wire and RG-59 or RG-6 coaxial cable for the video signal.

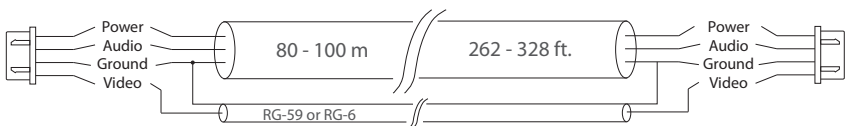

c) Shielded or non-shielded twisted pair (not recommended):

- distance up to 25 meters (82 ft.) non-shielded twisted pair can be used;

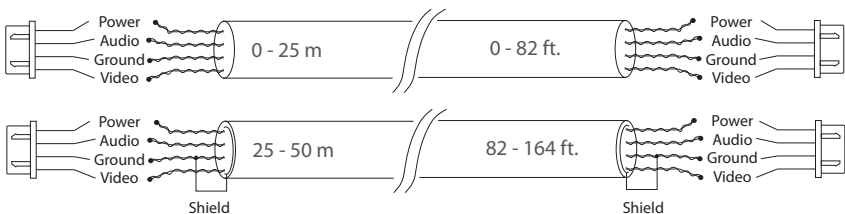

### 4.2. Schematic diagrams

Diagram 1. SQ-04N Cloud door panels, cameras and locks connection.

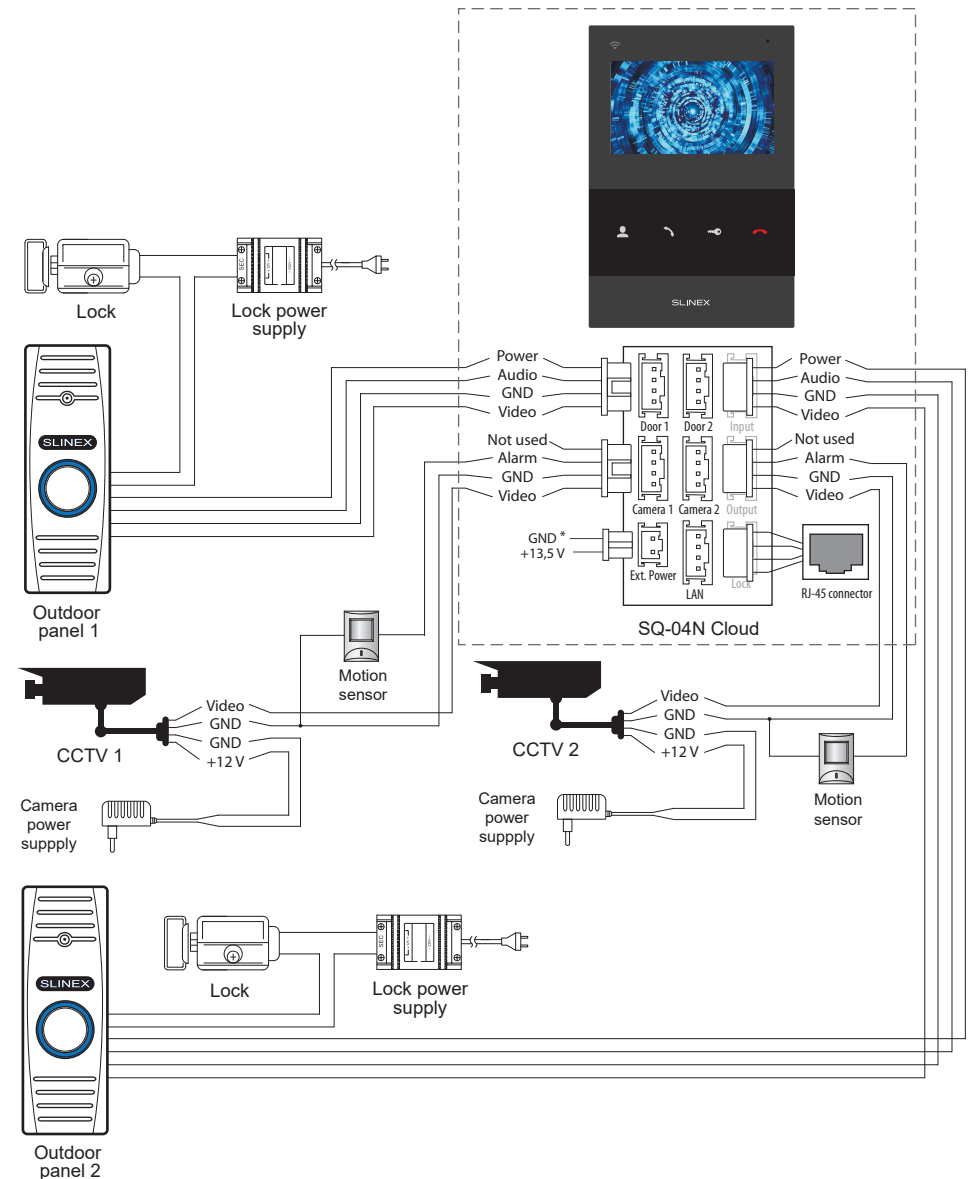
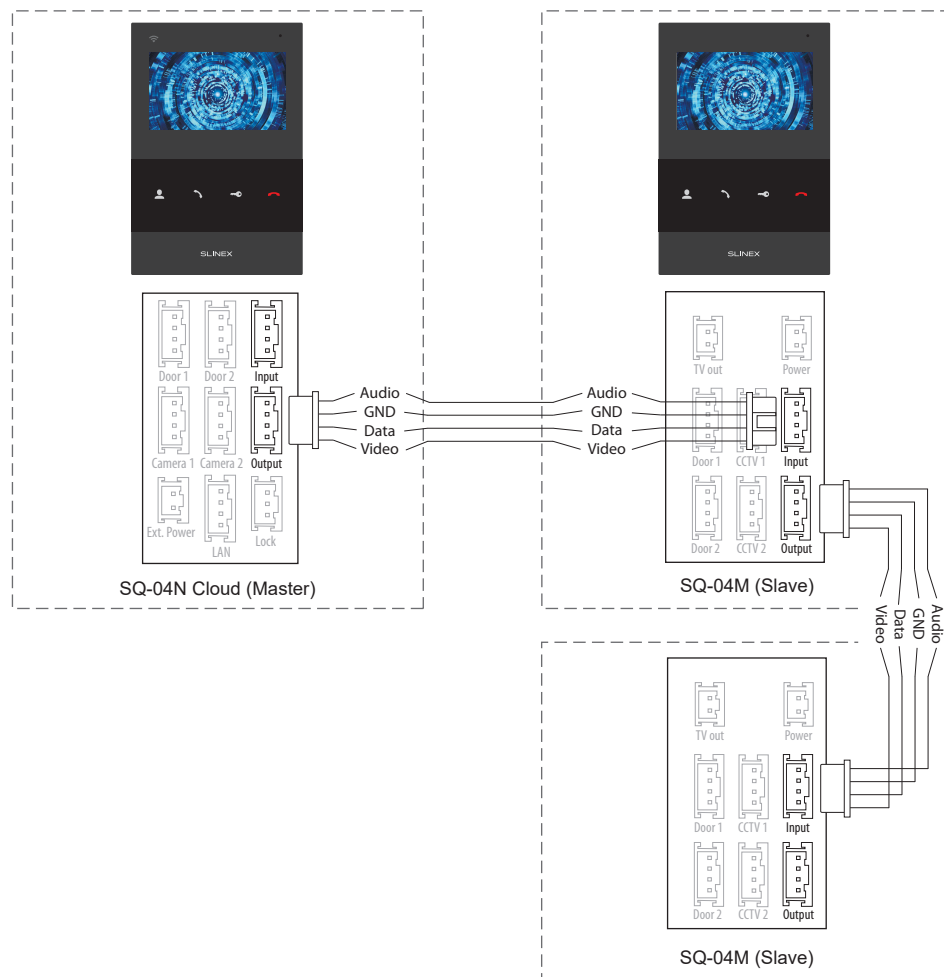

Diagram 2. SQ-04N Cloud system connection.



**Notes:**

\* Use «Power» plug on the monitor to connect external power supply +13,5 V. While use external power supply please keep main power cord ~100-240 V disconnected from the outlet, otherwise it can damage monitor circuits.

\*\* Door panels, cameras, power supplies, locks and motion sensors described on the schemes are optional devices and aren't included into monitors kit.

### 4.3. Unit mount

- 1) Take the surface mount bracket from the kit and situate it 150-160 cm from the floor line.
- 2) Mark and drill four holes in the wall.
- 3) Take four nuts from the kit and hammer them into the drilled holes.
- 4) Fix surface mount bracket on the wall by four screws from the kit.
- 5) Connect all communication wires and fix the monitor on the surface mount bracket.

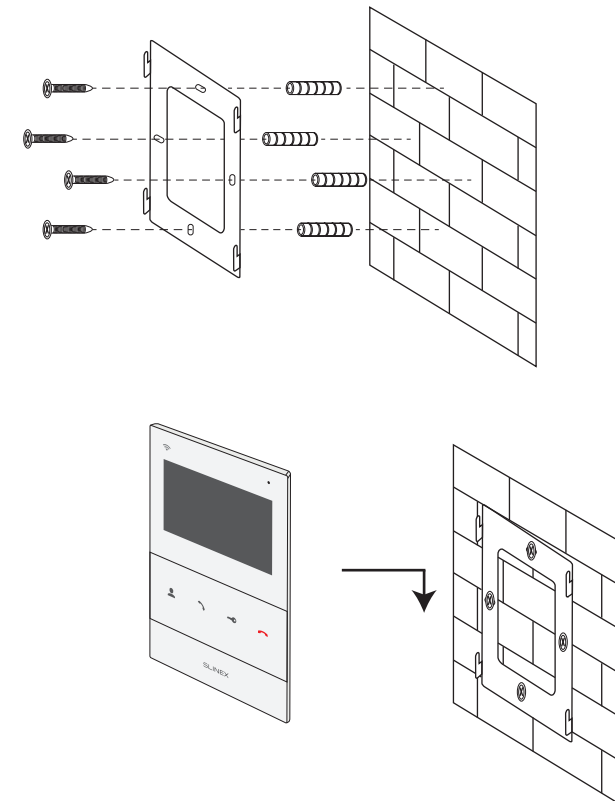

5. Operation

5.1. Incoming call

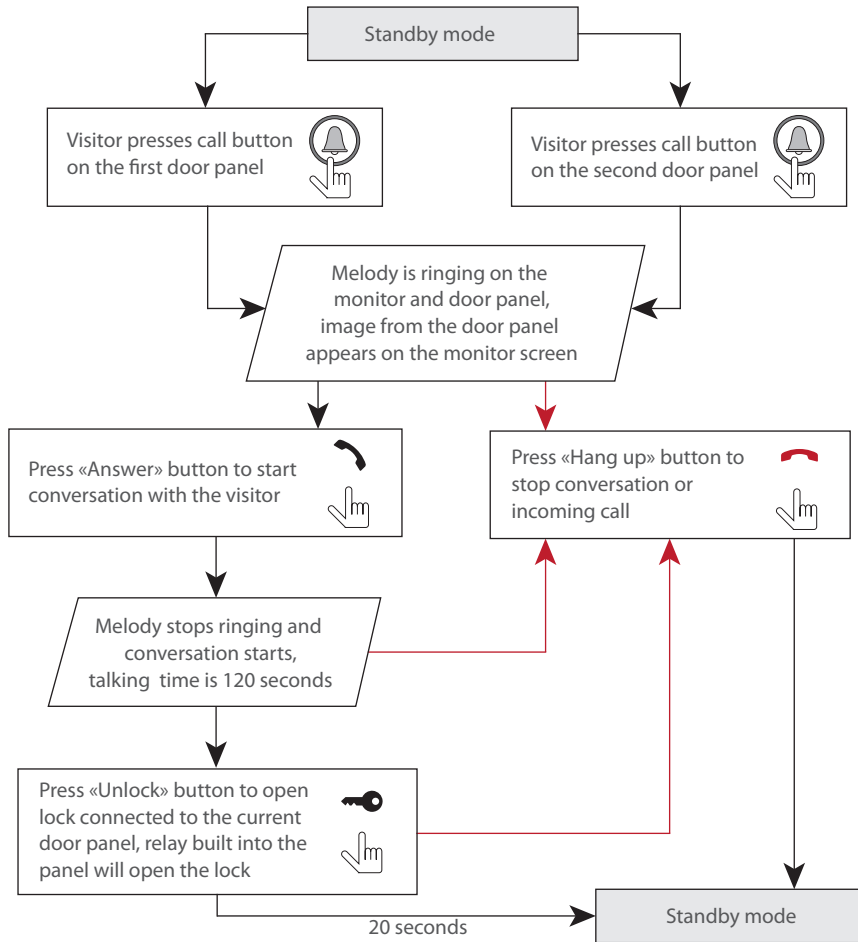

Notes:

- 1) Monitor will be automatically switched into standby mode if the user doesn't answer incoming call during 60 seconds;
- 2) Image and sound from the door panel will be active during 20 seconds after the moment user presses button. It let the user know if the visitor passed through the door.

5.2. Outdoor panel and camera image monitoring

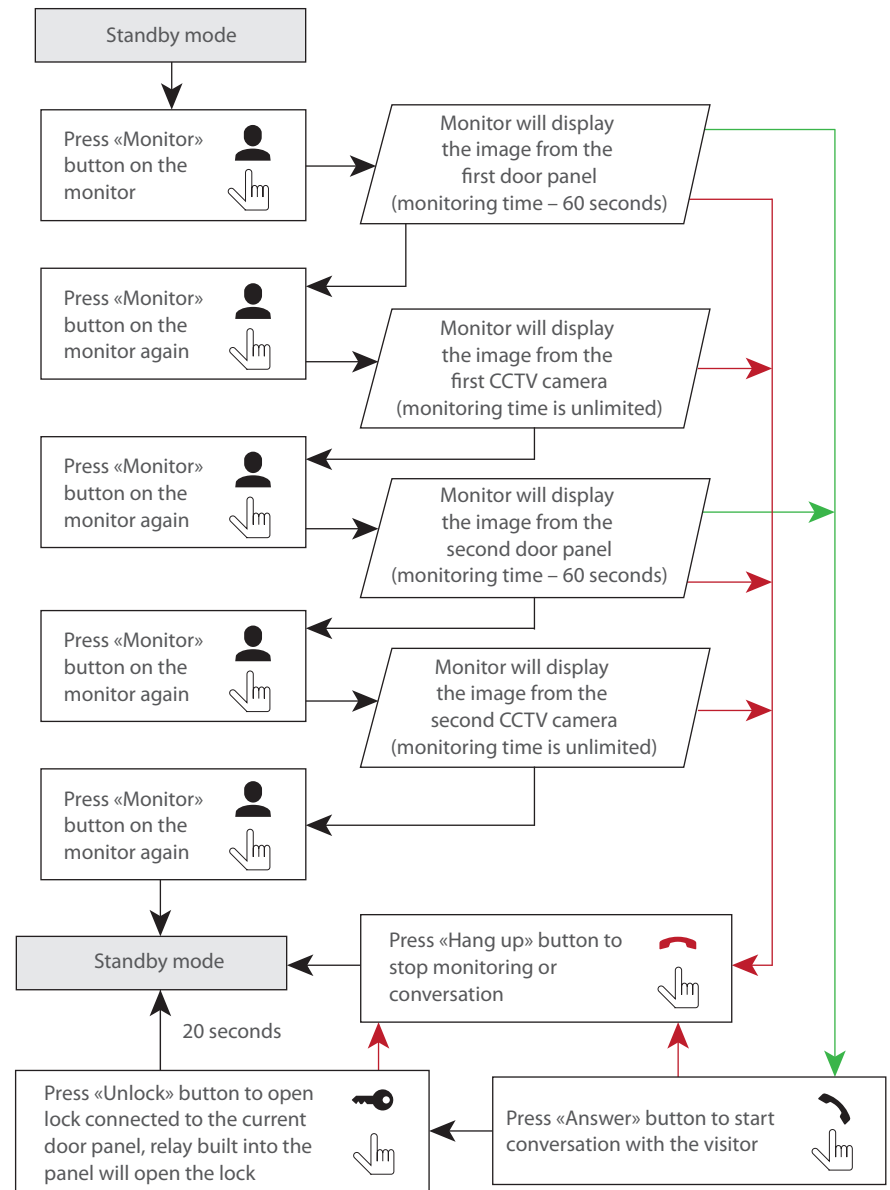

**Notes:**

- 1) If several monitors are connected into one system, user can view the image from the outdoor panels and cameras on any monitor inside this system. The image will be transferred from the «Master» monitor outdoor panels and cameras to the «Slave» monitors.
- 2) If someone press call button on the door panel while monitoring is active then the image from this outdoor panel appears on the monitor screen and call melody starts. Press «Answer» button to start conversation.

### 5.3. Incoming call redirection

Two monitors connected into one system are used.

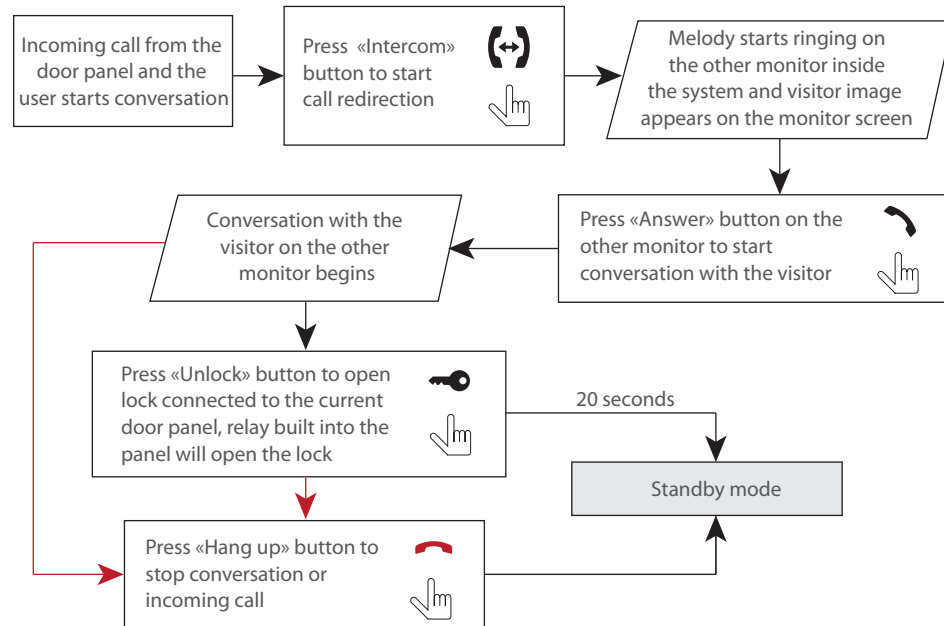

**Note:**

If incoming call is successfully redirected to the other monitor then current monitor will enter standby mode.

### 5.4. Intercom

Two monitors connected into one system are used.

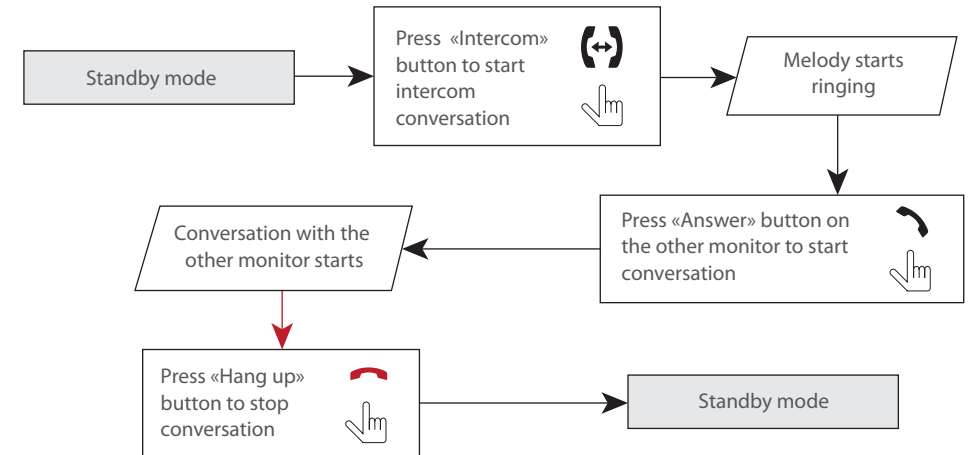

**Note:**

If somebody press call button on the door panel while intercom is active then the image from the door panel appears on the monitor screen and call melody starts. Press «Answer» button to start conversation with the visitor.

### 6. Main menu

Settings joystick situated on the right side of the monitor case. It has several functions:

- press the joystick in stanby mode to enter monitor settings;
- move the joystick up or down to choose different parameters of the monitor settings;
- press the joystick again to choose current parameter and move it up or down to change parameter value;
- press the joystick one more time to save current parameter value;
- press the joystick in monitoring or conversation mode to make a snapshot or start video recording. Press the joystick again to stop video recording.

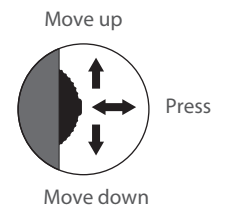

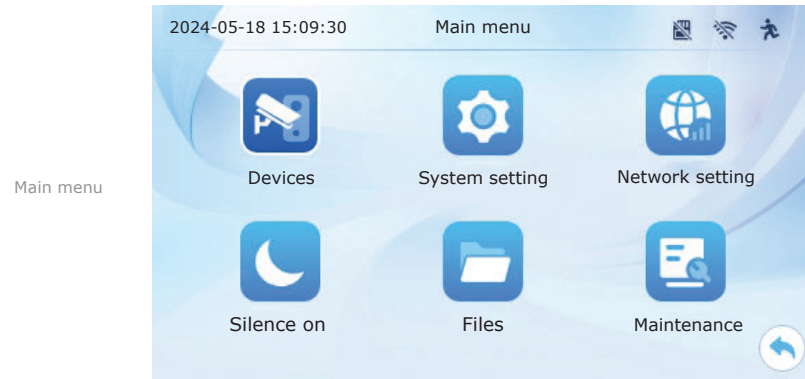

## 6.1. Devices

Press «Devices» icon in the main menu to enter devices settings:



### Main menu → Devices → Door 1 (Door 2)

**Unlock time** – outdoor panel relay unlocking time, from 1 to 10 seconds;

**Video mode** – input video signal type, CVBS PAL / CVBS NTSC / TVI / CVI / AHD / AUTOMATIC;

**Record mode** – record type when incoming call or motion event occurs, «Snapshot» or «Video»;

**Motion detection sensitivity** – motion detection sensitivity level, Low / Medium / High / Off;

#### Ring setting:

**Time** – incoming call melody ringing time from 5 to 45 sec.;;

**Ring mode** – «Standard» default melodies or «Customize» user mp3 melodies from SD card;

**Ring select** – melody select;

**Ring volume** – set incoming call melody volume level on the monitor, from 0 to 10;

**Message** – if nobody answers incoming call and this function is enabled then visitor have 90 seconds to leave a video message for the user, «On» or «Off».

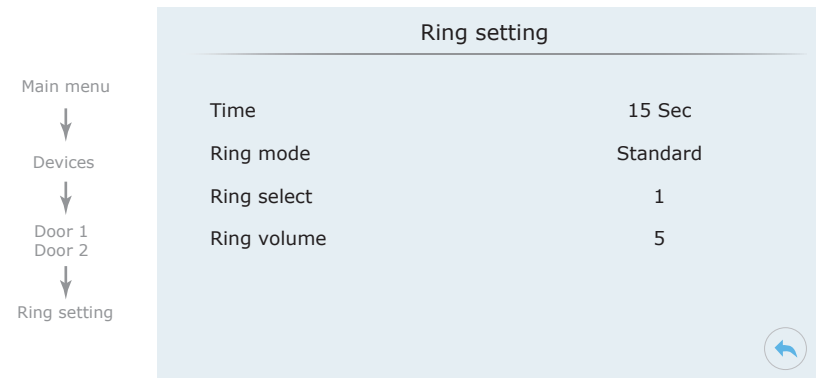
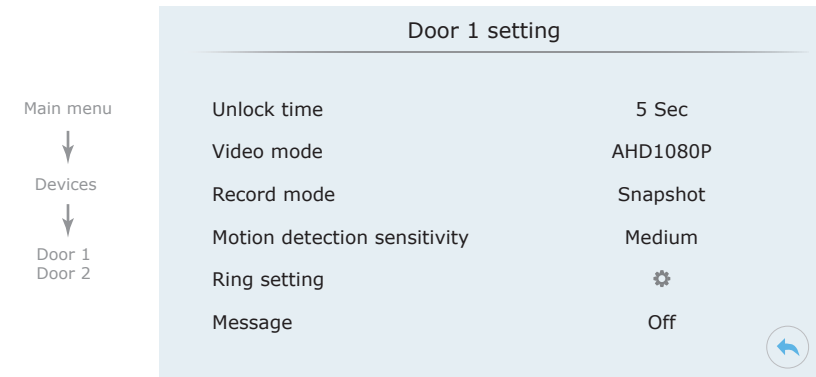

### Custom MP3 ringtone

Create «Ring» folder in the root of microSD card if it isn't already created by the monitor. Paste MP3 files you would like to use as a ringtone inside of the «Ring» folder. File names must have only English letters and figures in its names and its quantity must not exceed 8 symbols to be visible on the monitor.

Insert microSD card into the monitor and go to the «Main menu» → «Devices» → «Ring setting» menu. Then choose «Ring mode» → «Customize» and choose the melody to use as a ringtone in the «Ring select» menu.



## Main menu → Devices → Camera 1 (Camera 2)

**Status** – enable or disable current camera, «On» or «Off»;

**Video records** – input video signal type, CVBS PAL / CVBS NTSC / TVI / CVI / AHD / AUTOMATIC;

**Sensor type** – type of the sensor connected to the corresponding camera:

«NO», motion sensor with normally disconnected (opened) contacts is used;

«NC», motion sensor with normally connected contacts is used;

«Off», motion sensor is not used;

**Record mode** – record type when motion detection event occurs, «Snapshot» or «Video»;

**Motion detection sensitivity** – motion detection sensitivity level, Low / Medium / High / Off;

**Alarm time** – alarm ringing time from 5 to 45 seconds;

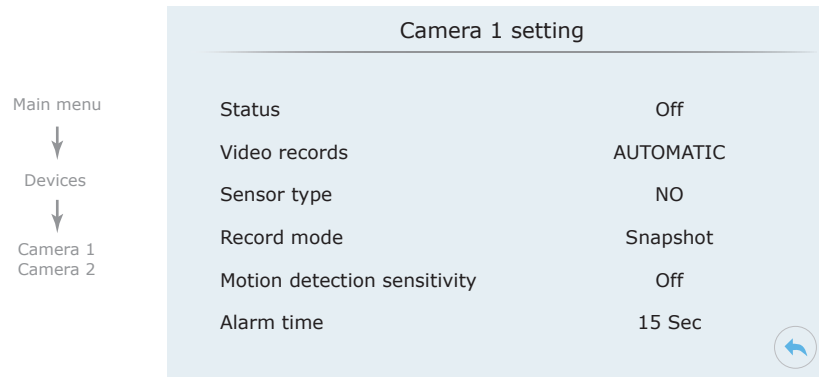

## 6.2. System setting

Press «System setting» icon in the main menu to enter system settings:

### Main menu → System setting

**Device ID** – 1 is the master monitor, 2 is the slave monitor;

**Time** – current date and time settings;

**Date format** – date format setting;

**Standby clock** – clock display in standby mode time, from 10 to 180 sec. or «Off»;

**Language** – menu language setting;

**Door panel backlight** – standby voltage on the outdoor panel, can be 5V, 12V or «Off»;

**Key backlight** – enable/disable keyboard backlight of the monitor;

**Keystone** – enable/disable keyboard touch sound;

**Indoor unlock time** – built in monitor relay unlocking time, from 1 to 10 seconds.

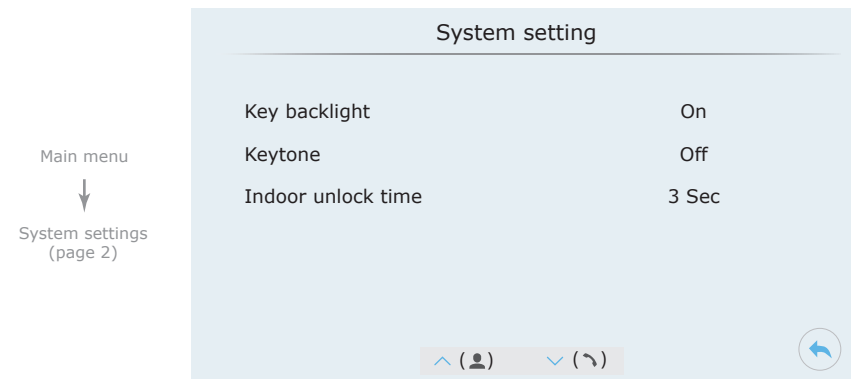
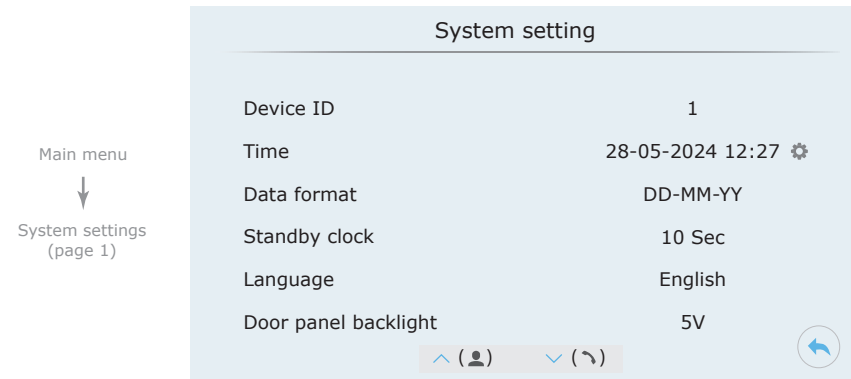

## 6.3. Network setting

Press «Network setting» icon in the main menu to enter network settings:

### Main menu → Network setting

**Net pairing mode** – monitor network connection mode,

«AP mode» – manual Wi-Fi connection mode;

«Cable» – wiring connection to the local network;

«EZ mode» – automatic Wi-Fi connection mode;

**Wi-Fi hotspot** – hotspot name;



**Password** – hotspot password;

**IP address** – device network IP address (available only in «Cable» and «EZ mode»);

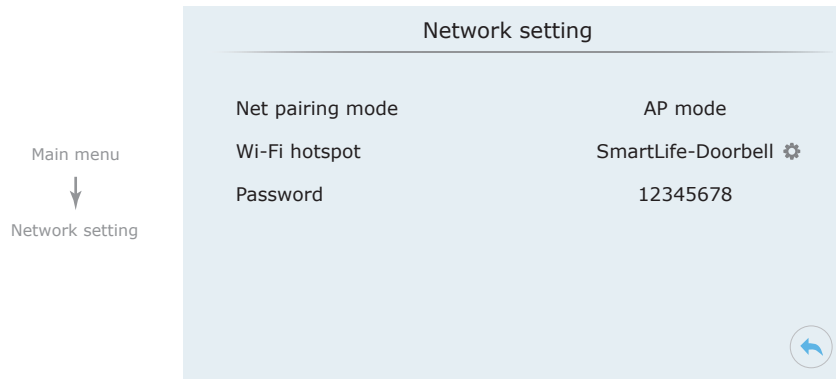
**MAC** – device MAC address (available only in «Cable» and «EZ mode»).



### 6.4. Silent mode

Press «Silence off» or «Silence on» icon in the main menu to enable or disable silent mode. In this mode there is no ringtone of incoming call on the monitor. In case of incoming call only image appears on the screen. Press  button to start conversation with the visitor or press  button to hang up the call.

### 6.5. Files playback

Press «Files» icon in the main menu then press «Video records» or «Snapshots» folder and choose the record folder type:

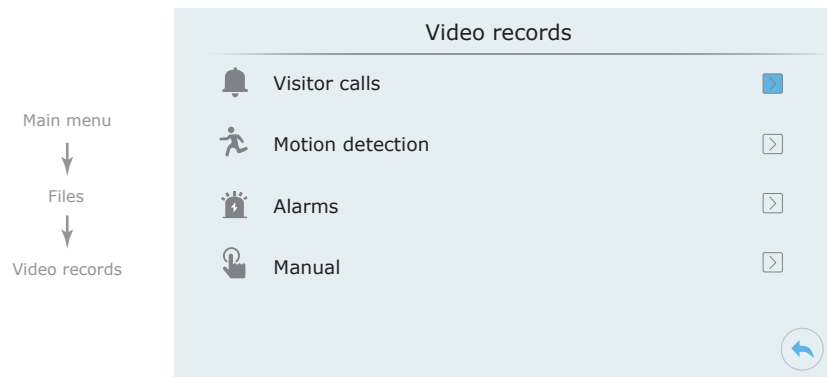

Choose the file from the files list by moving  joystick up or down and then press the joystick to enable context menu:

Play - start current file playback;

Delete - delete current file;

Delete all - delete all the files;

Cancel - disable context menu.

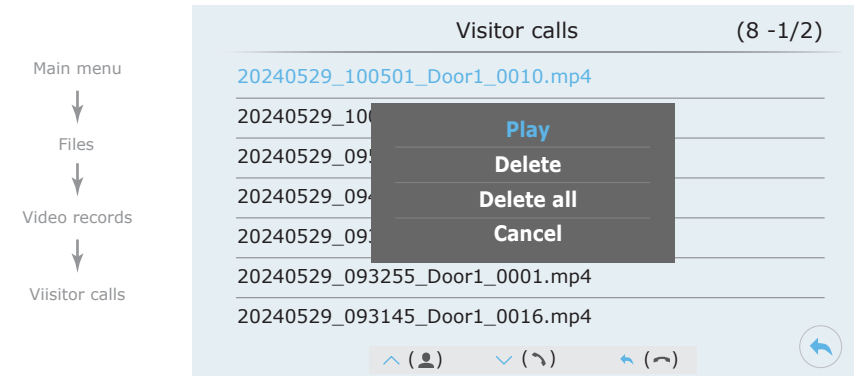

### 6.6. Maintenance

Press «Maintenance» icon in the main menu to enter maintenance menu:

**Main menu → Maintenance**

**Format SD card** – delete all the files from the microSD card;

**Factory reset** – restore monitor factory settings;

**Software update** – copy the update file into the root folder of the micro SD card and start software update;

**Restart system** – restart monitor software;

**Software version** – current software version of the monitor;

**Release date** – software release date;

**UUID** – unique cloud identification number;

**PID** – cloud domain identification number;

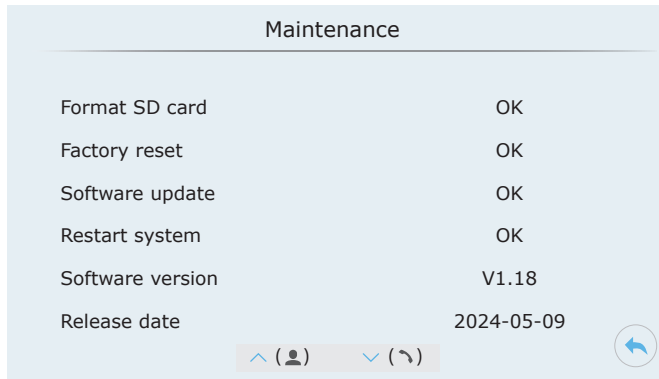

### 7. Image and talking volume settings

While outdoor panel or camera image monitoring press joystick on the right side of the monitor to enable image and talking volume settings bar. Move joystick up or down to change parameters and press it to choose current parameter and change its value. Change parameter value by moving joystick up or down and press the joystick again to save current parameter value.

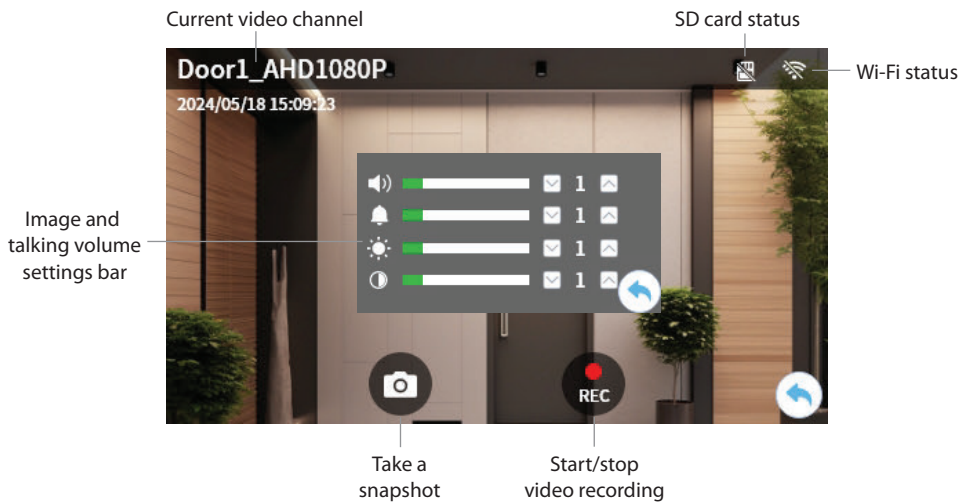

### 8. Network connection diagrams

Diagram 1. SQ-04N Cloud wired network connection.

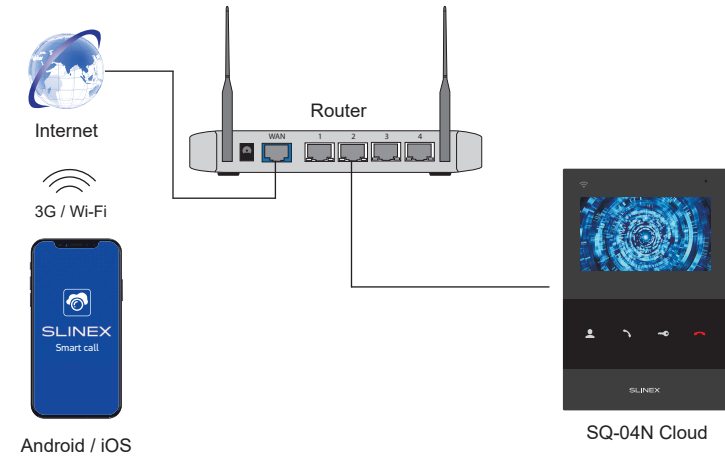
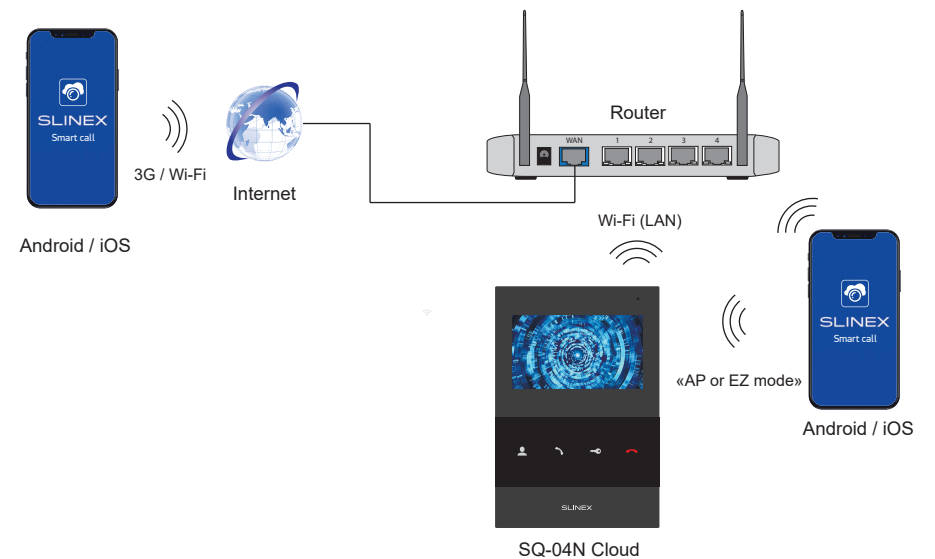

Diagram 2. SQ-04N Cloud wireless Wi-Fi network connection.



## 9. Software

Enter «Google Play» (for Android) or «Apple App Store» (for iOS) and search for «Smart Call» application, then install this application on your mobile device.

### 9.1. New account registering

- 1) Start «Smart Call» application on your mobile device and press «Sign up» button to create an account;
- 2) Choose destination country and enter your Email, then press «Get verification code» button to receive an Email with verification code;
- 3) Check the Email, specified on the previous step;
- 4) Enter 6-digit code from the letter to activate your account. Set your password and press «Finish» to finalize account creation process. Use your Email as a login for

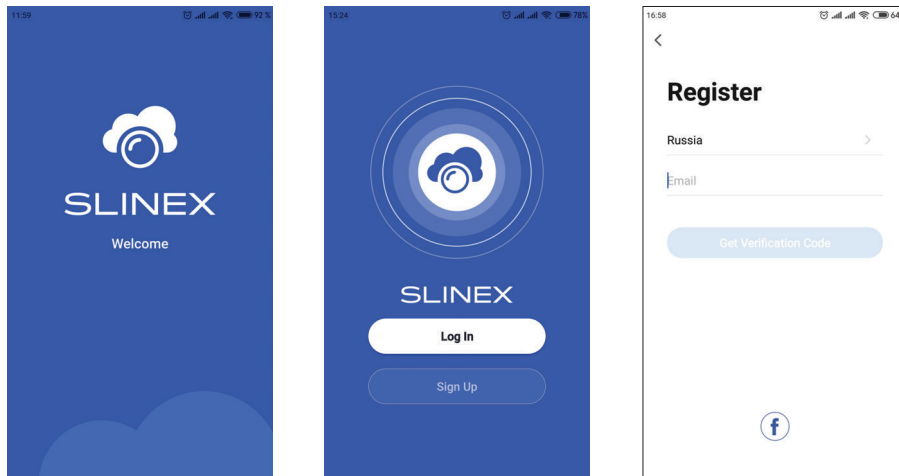

### 9.2. Wired network connection steps

- 1) Use twisted pair CAT5 or CAT6 cable to connect device to the router;
- 2) Connect mobile device into the same local network;
- 3) Press «Add device» button and choose device model for connection. Then choose «Cable» connection type in the upper right corner;
- 4) Turn on the monitor power and press «Next» button in the application;

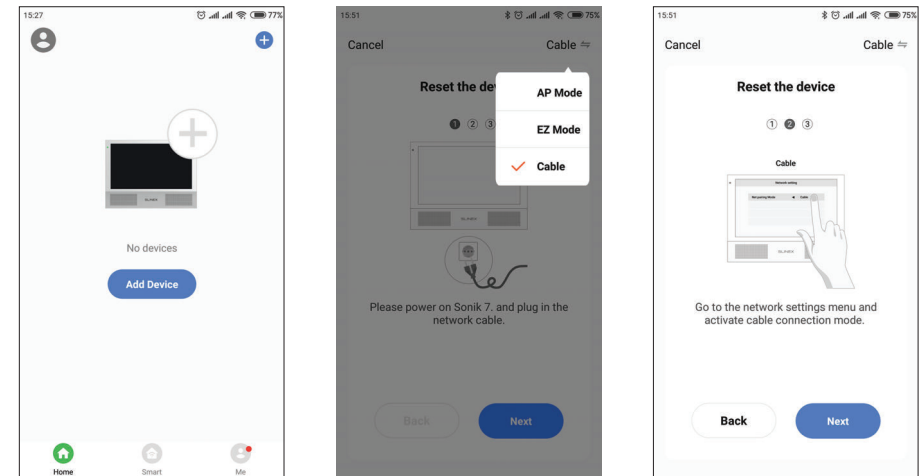

- 5) In the monitor main menu press «Settings» → «Network setting» → «Net pairing mode» set «Cable» type of connection. Monitor will reboot after exiting «Network» menu. After monitor reboot press «Next» button in the «Smart Call» application;
- 6) Enable «Next step» switch then press «Next» button. Network devices search will be started;
- 7) Choose Sonik7 Cloud device in the list and it will be paired to the current account of the «Smart Call» application.

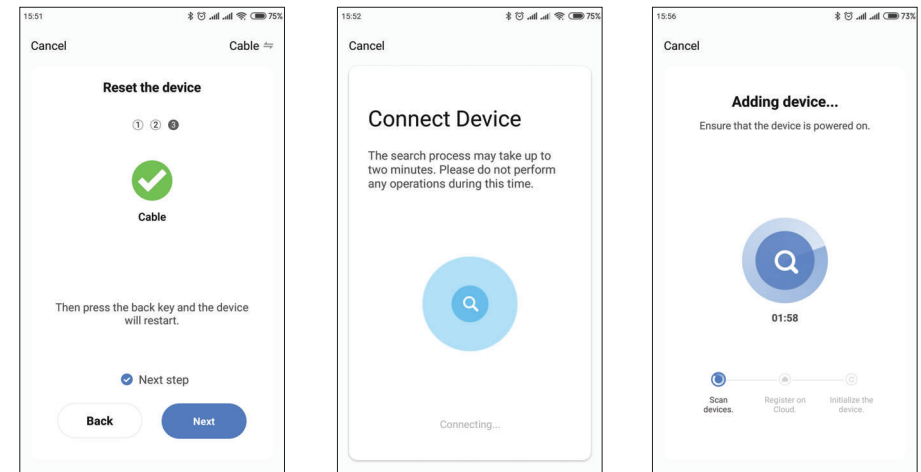

9.3. Wireless Wi-Fi network connection steps in «AP mode»

- 1) Connect mobile device into the same Wi-Fi network you want to connect the monitor;
- 2) Disable 3G/4G internet connection on your mobile device;
- 3) Press «Add device» button and choose device model for connection;
- 4) Turn on the monitor power and press «Next» button in the application;
- 5) In the monitor main menu press «Settings» → «Network setting» → «Net pairing mode» set «AP mode» type of connection. Monitor will reboot after exiting «Network» menu. After monitor reboot press «Next» button in the «Smart Call» application;
- 6) Enable «Next step» switch then press «Next» button;

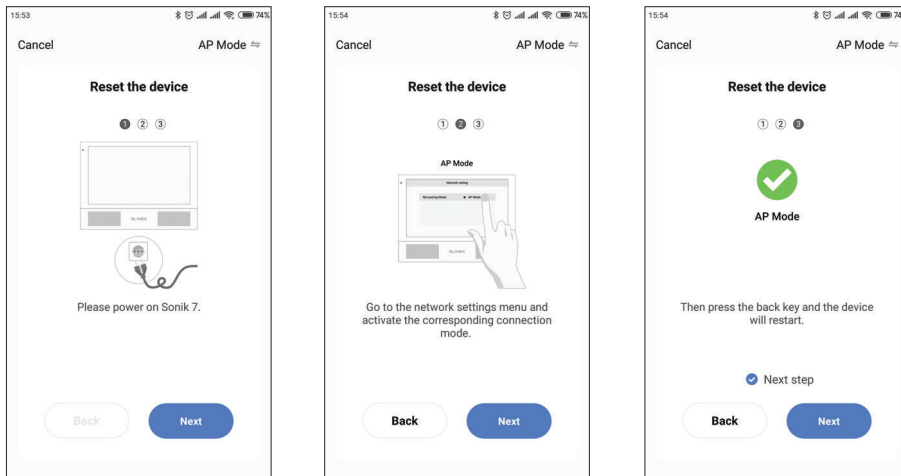

- 7) Enter Wi-Fi network name, the monitor will be connected to, and network password. Then press «Next» button to go to the next step;
- 8) Press «Go to connect» button and manually connect mobile phone to the Wi-Fi hotspot of the monitor. Wi-Fi hotspot name is «SmartLife-xxxxxx». Password: 12345678;
- 9) When mobile phone is connected to the Wi-Fi hotspot, come back to the mobile application. The monitor will be connected to the Wi-Fi network, specified on the 7-th step and paired to the current account of the «Smart Call» application.



If current device is already paired to some account in the «Smart Call» application, then it is impossible to add this device to any other account. To add this device to some other account delete this device in the account, it is currently connected to!

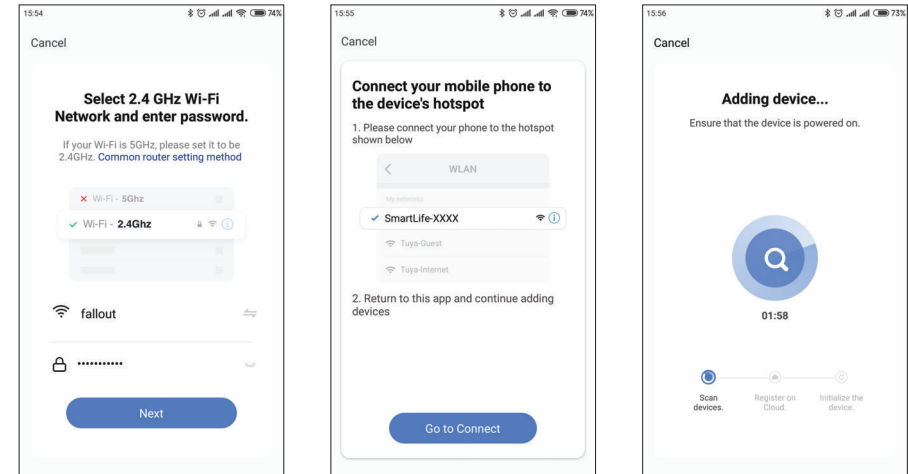

9.4. Wireless Wi-Fi network connection steps in EZ mode

- 1) Connect mobile device into the same Wi-Fi network you want to connect the monitor;
- 2) Disable 3G/4G internet connection on your mobile device;
- 3) Press «Add device» button and choose device model for connection. Then choose «EZ mode» connection type in the upper right corner of the screen;
- 4) Turn on the monitor power and press «Next» button in the application;
- 5) In the monitor main menu press «Settings» → «Network setting» → «Net pairing mode» set «EZ mode» type of connection. Monitor will reboot after exiting «Network» menu. After reboot press «Next»

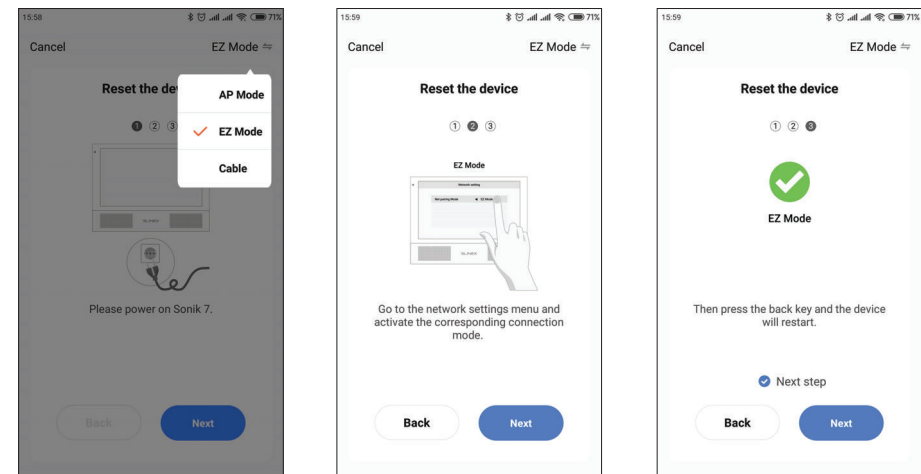

- button in the application;
- 6) Enable «Next step» switch then press «Next» button;
  - 7) Enter Wi-Fi network name, the monitor will be conected to, and network password. Then press «Next» button to go to the next step;
  - 8) The monitor will be connected to the Wi-Fi network, specified on the 7-th step and paired to the current account of the «Smart Call» application.

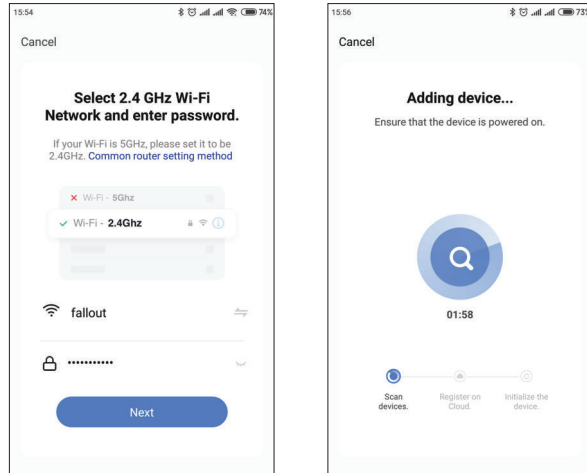

## 9.5. Operation

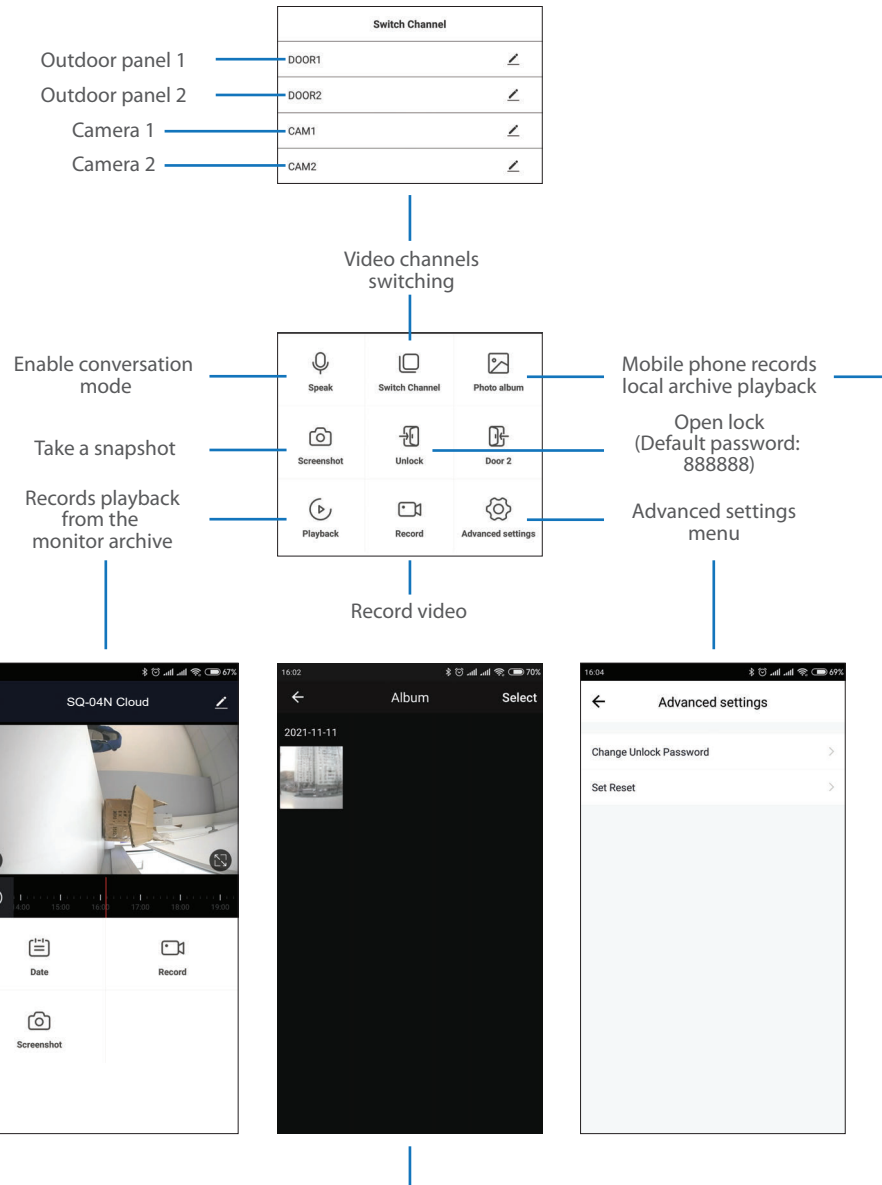
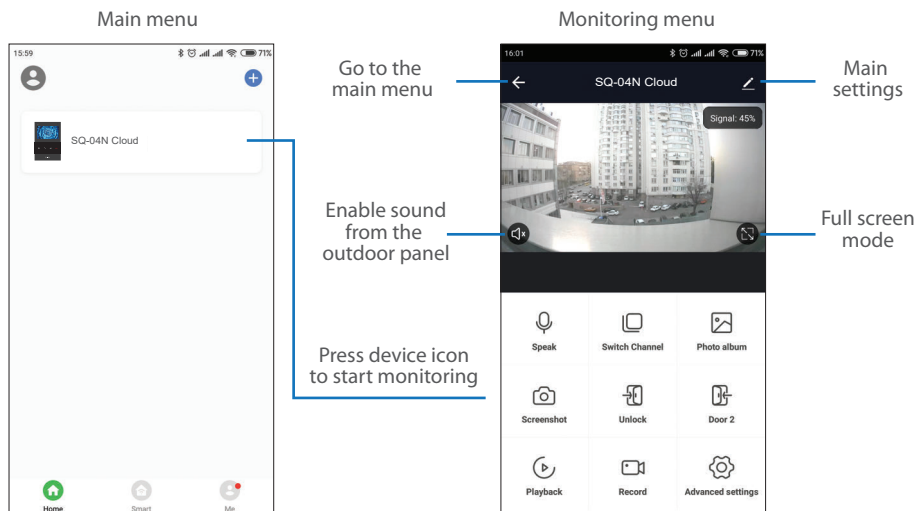

9.6. Sharing with the other devices

The account, device is added for the first time, is master account. This account has master permissions and can change all the settings. If several mobile phones are going to be used with the same device then personal account must be created on every mobile phone. Here are the steps to add the same device on several mobile phones:

- 1) Create an account on the first mobile phone application and add your device. Account on this mobile phone will be the master account for this device;
- 2) Install «Smart Call» application on every mobile phone that is going to be used and create its own account in every application. Every mobile phone must use it's own account in the application;
- 3) Using master account enter device monitoring screen, press  icon on the right upper corner of the screen and enter «Add sharing» menu. Enter account name, used on the shared device and press «Done» button on the right upper corner of the screen. Shared account must be added to the sharing list. It means that the user on the shared mobile phone now have an access to this device;
- 4) In the same manner add all other mobile devices into sharing list.

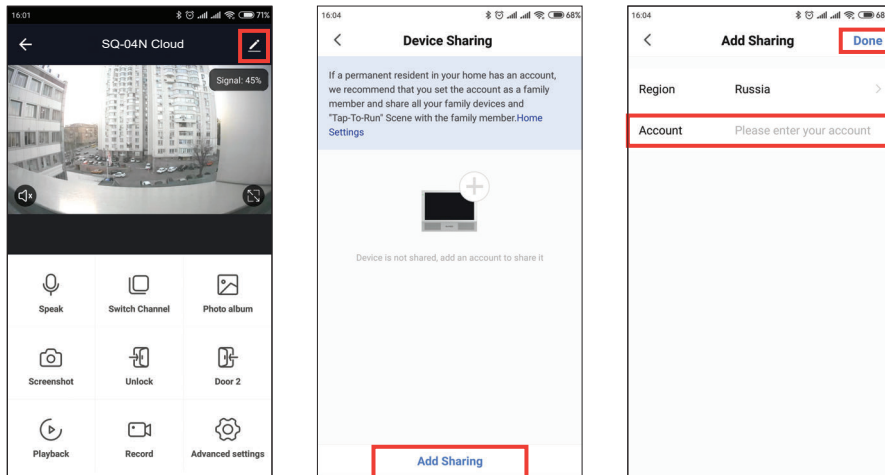

9.7. Notification messages

Press «Me» bookmark on the bottom of the main screen, then press  icon on the right upper corner of the screen and enter «App Notification» menu. Here you can enable or disable notification messages from the application.

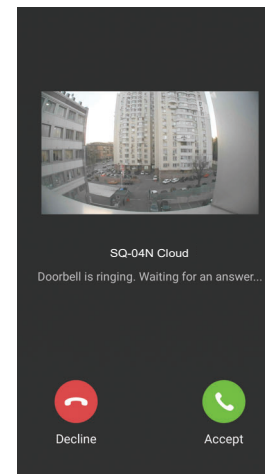
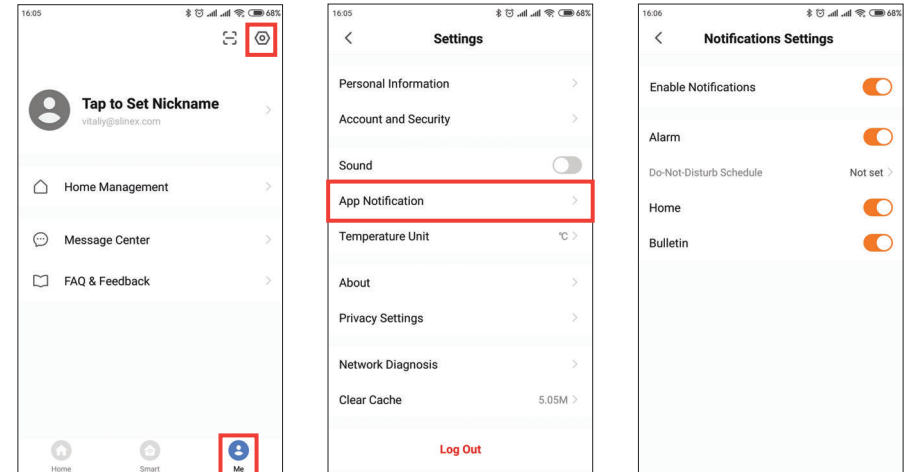

Press «Accept» button to start conversation with the visitor or «Decline» to hang up incoming call.

## 10. Limited warranty

Manufacturer guarantees product normal functioning during the warranty period if the user keeps all safety instructions described in that manual.

Warranty period is 12 months from the moment of the product purchasing (warranty period could be extended up to 24 months or more, depending on the local regulations).

Warranty period allows user to make guarantee repair in cases when normal functioning of the product was violated by the fault of manufacturer and the user has not offend transporting, installation and working conditions.

This limited warranty does not cover any damage to the product that results from improper installation, accident, abuse, misuse, natural disaster, insufficient or excessive electrical supply, abnormal mechanical or environmental conditions, or any unauthorized disassembly, repair or modification.

Warranty void in such cases:

- the product was damaged by the fault of the customer;
- the product wasn't properly installed according recommendations from the manual;
- the sticker on the backside of the product was broken;
- the product was not used for its intended function.

This limited warranty covers only repair, replacement, refund or credit for defective products, as provided above. Manufacturer is not liable for, and does not cover under warranty, any damages or losses of any kind whatsoever resulting from loss of, damage to, or corruption of, content or data or any costs associated with determining the source of system problems or removing, servicing or installing products. This warranty excludes third party software, connected equipment or stored data. Manufacturer is therefore not liable for any losses or damage attributable to third party software, connected equipment or stored data.

In the event a product has been discontinued, manufacturer shall either repair the product, offer to replace it with a comparable product or provide a refund at the lesser of the purchase price or the product's current value.

Repaired or replacement products will continue to be covered by this limited warranty for the remainder of the original warranty term.